



MAINLINE®

Preferred by the pros.™

XD

Two Handle Mop Service Sink Faucet

SPECIFICATIONS



Features

- Max Flow Rate : 4GPM (15.14L/Min) @ 60 PSI
- Fits 2 Hole
- Fits 8" Center Holes
- Polished Chrome Handles
- Brushed Chrome Body
- ADA

Components

- Metal Wrist Blade Handles
- Vandal Resistant Handles
- Integral Stops & Vacuum Breaker
- Includes Pail Hook
- ¾" Hose End
- Metal Body
- Ceramic Cartridge
- Lead Free*
- Solid Brass Waterways

Drain Type

N/A

MLE141XD-RC

Standards & Certifications

✓	✓	✓	✓

Available Finishes

✓			

Mount Type

			✓

Specified model meets or exceeds the following:

- ASME A112.18.1/CSA B125.1
- IAPMO/cUPC
- ADA
- *≤ .25% Pb

AVAILABLE MODELS

Mainline products have been manufactured under the highest standards of quality and workmanship. That is why we offer a "Limited 5 Year" warranty on the function and finish of our faucets.



Please visit www.mainlinecollection.ca for available finishes. Finish is defined by additional suffix.

Drawings

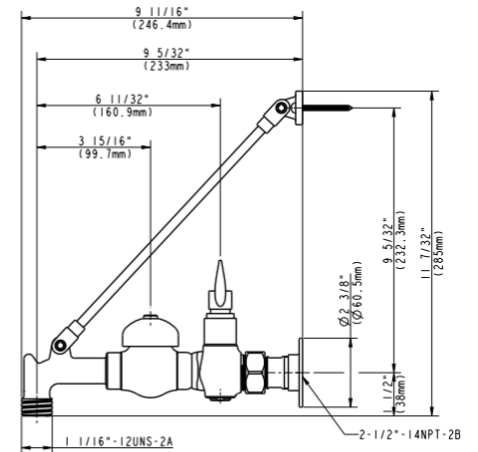
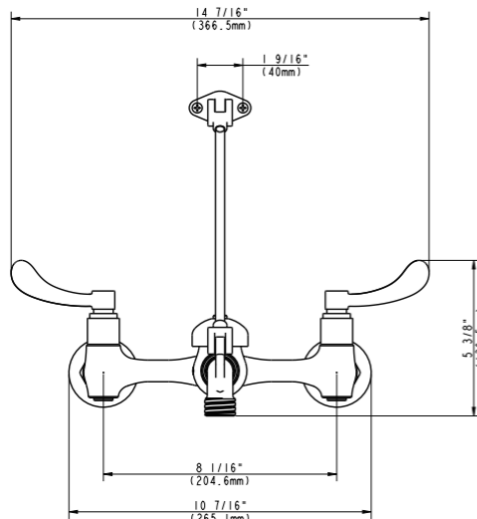

SUBMITTAL INFORMATION

Name: _____ Contractor: _____

Location: _____ Contact #: _____

Notes: _____

Service & Parts

Please reach out to epleservice@emcoltd.com for support/ visit mainlinecollection.ca / CANADA +1 (450) 621 5636